



DISAB TrailerVAC™ SET-20T

Usage

The DISAB TrailerVAC™ SET-20T units are a series of mobile, electrical powered vacuum loaders that are fitted onto trailer chassis. Suitable for suctioning both dry and liquid materials for any industrial application. When connected to a fixed pipe system, these units can operate as a perfect central vacuum unit for industrial installations.

Typical users include manufacturers of cement, lime, gypsum, tiles, chemicals, steel mills, cleaning contractors and more.

Characteristics

The DISAB TrailerVAC™ SET-20T is a great choice for industrial settings where cleaning needs to be done in multiple locations/buildings. It is easy to transport, provides good suction capacity, and a large collecting hopper volume, which is placed onto a trailer for towing by a tractor or similar makes the whole unit easy to transport as it is operational as soon as hose/pipe is connected together with an electrical power plug. Also, the handling of the dust is easily carried out as there is a built-in tipping cylinder for the discharge.

Benefits

A DISAB TrailerVAC™ SET-20T unit is suitable for use in any heavy industrial application where collection of dust is required i.e. to clean out; deep pits, trenches, bucket elevators, conveyor spills, overhead cranes and runways, dust collectors, processing machines etc. The unit is specially suitable where bulky or sticky material shall be collected due to its convenient discharging.

Other benefits include:

- Roots-type high vacuum pump (50-80%)
- Filter system for dry and wet material
- Automatic filter cleaning without compressed air
- Electrical motor, 55 to 90 kW
- Built-in tipping cylinder for easy discharge
- Large pick-up capacity
- Very low noise level due to well insulated motor compartment housing
- The vacuum pump is equipped with a spring loaded safety valve regulating the vacuum not to exceed its maximum operating range.
- The filter system is equipped with a vacuum controlled ATM (air-repulse) filter cleaning system.

A DISAB TrailerVAC™ SET-20T meets the high demands from the industry due to its efficiency, reliability, ease of operation and maintenance giving excellent value for money.

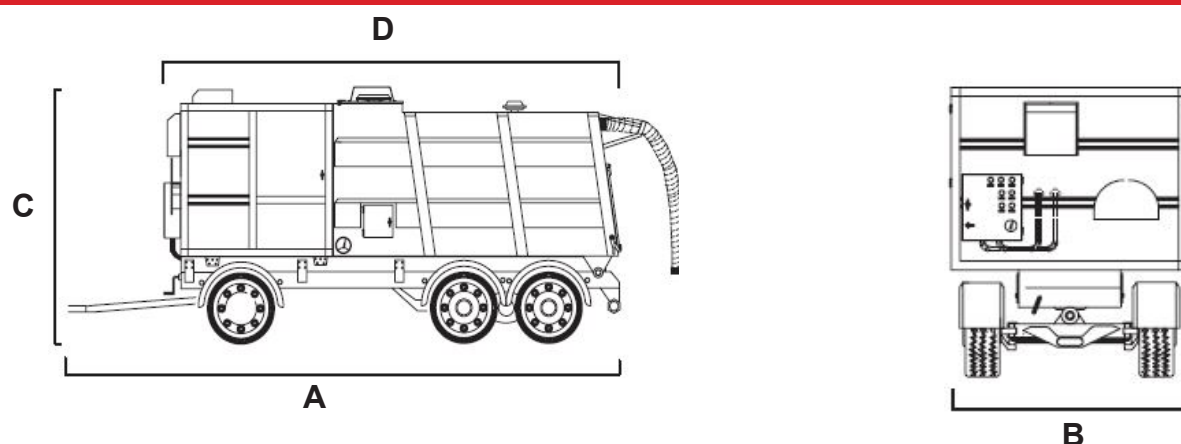

Technical Data Chart for DISAB TrailerVAC™ SET-20T

| Weight and Dimensions | SET-20T.55 | SET-20T.75 | SET-20T.90 |
|-----------------------|------------|------------|------------|
| A | 7 800 | | |
| B | 2 455 | | |
| C | 3 190 | | |
| D | 6 570 | | |
| Weight, kg (approx) | 8 700 | 8 800 | 8 950 |

Description

| | Three-Lobe Roots Pump | | |
|--|---|-------|-------|
| Vacuum pump | Three-Lobe Roots Pump | | |
| Max vacuum, mbar | 500 | 500 | 500 |
| Air volume m3/h (unloaded) | 3 360 | 4 625 | 5 180 |
| Electrical Motor, kW | 55 | 75 | 90 |
| Voltage Frequency, V/Hz | 400/50 | | |
| Tank volume (m ³)* *Excluding filter volume | 10 | | |
| Total Tank Volume (m ³) | 12 | | |
| Tank tipping system | Hydraulic front cylinder, double acting system. Tailgate is hydraulically operated and locked. | | |
| Main filter system (m ²) | 24 | | |
| Safety filter surface (m ²) | 30 | | |
| Noise Level dB(A) (at 1m/5 m distance) | 72 | | |
| ATEX approved | On request | | |

Miscellaneous

| | |
|------------------|-------------------------|
| Trailer | 21 tonnes capacity |
| Filter Class | L, M IEC EN 60335-2-69 |
| Hose connect | Dia 152 mm or smaller |
| Material | Steel S 235 JG2 |
| Painting | System C2, RAL 3003 red |
| Max Towing Speed | 30 km/h |