



DISAB TrailerVAC™ SDT-20T

Usage

The DISAB TrailerVAC™ SDT-20T units are a series of mobile, diesel powered vacuum loaders that are fitted onto trailer chassis. Suitable for suctioning both dry and liquid materials for any industrial application. When connected to a fixed pipe system, these units can operate as a perfect central vacuum unit for industrial installations.

Typical users include manufacturers of cement, pulp- and paper industry, gypsum, tiles, chemicals, steel mills, cleaning contractors and more.

Characteristics

The DISAB TrailerVAC™ SDT-20T is a great choice for industrial settings where cleaning needs to be done in multiple locations/buildings. The large hopper placed on a trailer for towing by a tractor or similar makes the whole unit easy to transport. The unit can start operating as soon as a hose/pipe is connected.

Also, the handling of the dust is easily carried out as there is a built-in tipping cylinder for the discharge.

Benefits

A DISAB TrailerVAC™ SDT-20T unit is suitable for use in any heavy industrial application where collection of dust is required i.e. to clean out; deep pits, trenches, bucket elevators, conveyor spills, overhead cranes and runways, dust collectors, processing machines etc. The unit is specially suitable where bulky or sticky material shall be collected due to its convenient discharging.

Other benefits include:

- Roots-type high vacuum pump (50-80%)
- Filter system for dry and wet material
- Automatic filter cleaning without compressed air
- Donkey engine
- Engine power 130 or 160 kW
- Large dustbins with tailgate for easy discharge
- The vacuum pump is equipped with a spring loaded safety valve regulating the vacuum not to exceed its maximum operating range.
- The filter system is equipped with a vacuum controlled ATM (air-repulse) filter cleaning system.

A DISAB TrailerVAC™ SDT-20T meets the high demands from the industry due to its efficiency, reliability, ease of operation and maintenance giving excellent value for money.

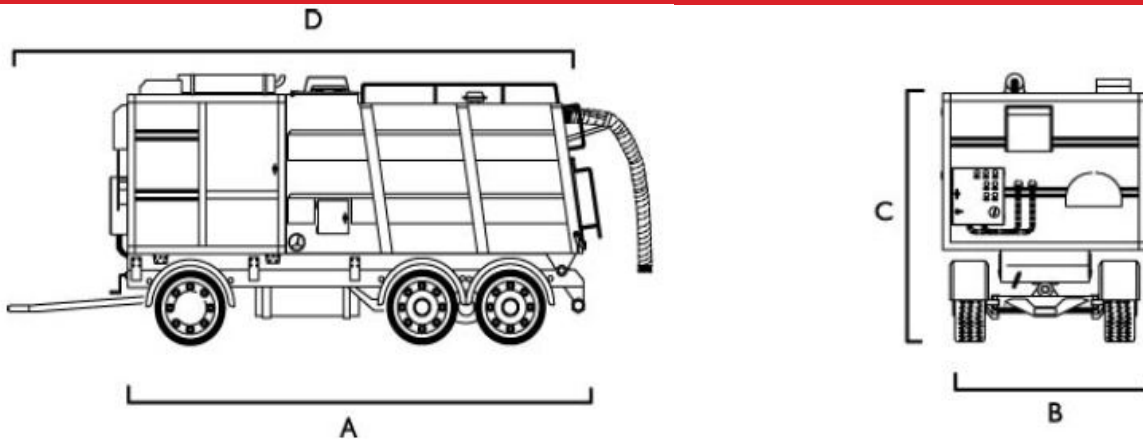

Technical Data Chart for DISAB TrailerVAC™ SDT-20T

Weight and Dimensions	SDT-20T.130	SDT-20T.160
A (mm)	6,650	
B (mm)	2,455	
C (mm)	3,300	
D (mm)	8,500	
Weight, kg (approx)	11,450	12,000

Description

Vacuum pump	Three-Lobe Roots Pump	
Max vacuum, mbar	800	
Air volume m ³ /h (unloaded)	4,600	6,650
Engine Power, kW	129 (IV)	168 (III A)
Tank volume (m ³)* *Excluding filter volume	10	
Total Tank Volume (m ³)	12	
Tank tipping system	Hydraulic front cylinder, double acting system. Tailgate is hydraulically operated and locked.	
Main filter system (m ²)	24	
Safety filter surface (m ²)	27	36
Noise Level dB(A) (at 1m/5 m distance)	84	85
ATEX approved	On request	

Miscellaneous

Trailer	21 tonnes capacity	
Filter Class	L, M IEC EN 60335-2-69	
Hose connect	Dia 152 mm or smaller	
Material	Steel S 235 JG2	
Painting	System C2, RAL 3003 red	
Max Towing Speed	40 km/h	