



To increase the pick-up capacity of the SEBF-II units they can work in conjunction with pre-separators i.e. vacuum skips

Suction Unit SEBF-II

The SEBF-II suction units meet the high demands from the industry due to its efficiency, reliability, ease of operation and maintenance giving excellent value for money.

The SEBF-II units are a series of electrical powered vacuum that are mounted in a solid metal frame with telescopic legs. Together with a fixed pipe network this is a perfect central vacuum unit for smaller industry installations, but can also operate as a single suction unit using a 3 or 4" hose.

- Rigid design for industrial use
- Filter system which can handle dry and wet material
- Automatic filter cleaning without compressed air
- Several options for filters and other accessories
- Engine power ranging from 30 to 55 kW.
- Control panel placed in dust-tight enclosure.
- Optional discharge system for continuous discharge and closed handling.
- Telescopic legs adjustable in height to fit most dust receivers
- 63/125 amps electrical plug makes the unit usable in most industrial areas

WHY SEBF-II

A fork lift is usually available in all industrial companies and there are often bins available for dust and waste inside or outside the works. The SEBF-II Discharge System can easily be connected to most bins, bags or similar, which makes the SEBF-II the most suitable choice. The high suction capacity together with its flexible discharge system makes the unit very useful in most vacuum cleaning situations. Due to its flexibility the unit gets access to most areas where cleaning needs to be carried out without the use of a fixed pipe network, and is also suited for material that shall be recycled or collected in bags and similar.

OPERATION

Collected material in the filter unit compartment is emptied through either a mechanical bottom balance valve, or an optional pneumatic valve. A bin-level control can also be fitted. For discharging into a bag, hopper or other receiver, the legs of the unit are adjustable in height 1 m to allow placing a receiving bin under the discharge valve.

The units are equipped with a safety valve that through spring release opens at the max. vacuum. Unloading valves are mounted between the main filter system and the vacuum unit. The vacuum will immediately be equalised when the valves are opened and at the same time the main filters will be cleaned. This will also prevent counter-rotation of the engine. The unloading valves will always automatically open at stop and start. They will also be activated by safety control functions. All functions are controlled from the control panel and control LED:s and gauges will indicate the units operational status. The unit is handled by a fork lift, skip lorry or with a crane.

APPLICATIONS

For general cleaning and bulk suction in any industrial application where high capacity is required together with flexibility, mobility, reliability and low noise level.

TYPICAL USERS

Manufacturers of Cement, Lime, Gypsum, Tiles, Concrete, Chemicals, Plastics, Fertilizer and Alumina. Foundries, Steel mills, Pulp-and Paper Industry, Quarries, Bakeries, Work Shops, Contractors, Shipyards...

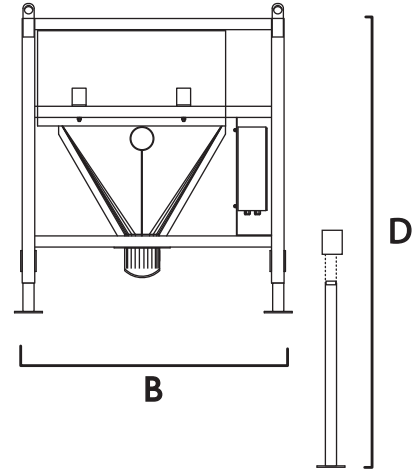
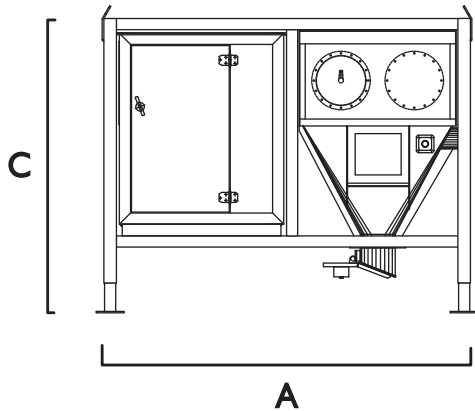

Suction Unit SEBF-II

VACUUM PUMP

The vacuum producer is of the Roots pump type, driven via V-belt transmission by an air-cooled electrical motor. Pump and motor are mounted on a anti vibrated steel structure, which also acts as the exhaust air silencer.

The vacuum pump is equipped with a spring-loaded safety valve, regulating the vacuum not to exceed its maximum operating range. For extra protection of the vacuum pump, high temperature sensor and safety filter are installed.

For service, the unit is fitted with large access doors on both sides.

FILTER SYSTEM

The main filter compartment contains a cassette filter with flat filter bags, made of specially treated polyester needle felt. Service of filters is easy from the clean air side and from outside of the unit.

The filter system is equipped with a vacuum controlled ATM (air-repulse) filter cleaning system. When activated, a large air inlet will ensure a fast backwards air direction through the filters, thus in an efficient way knocking off collected dust from the filter surface.

DUST BIN

Type: Conical hopper
Bin Volume: 1 m³ bin volume
Bottom flange: 250 mm
Discharge valve: Balanced flap valve as standard other upon request

MISCELLANEOUS

Electrical controls: 3-phase 400 V, 50Hz,
DOL starter with motor protective switch, steel enclosure IP 65 with gauge.

Filter class: L, M IEC EN 60335-2-69
Material: Steel S 235 JG2
Hose connect: Ø152 mm
Painting: System C2, RAL 3003 red

OPTIONS

- DP-Gauge Safety Filter
- DP-Switch Safety Filter
- Extra Noise Insulation for ATM Valve
- Jet Pulse Filter Cleaning
- Level Control; Paddle type or Vibrating type
- Line (Circuit) Breaker
- Pre Designed for Remote Control 24 V
- Radio Remote Control (CE, Carrier vave interr.)
- Star-Delta -Starter
- Temp Switch Motor
- Timer Auto Stop
- V-Belt Cover
- Vacuum Timer Stop
- Ventilator Cooling

Item/Model		SEBF-II.30	SEBF-II.37	SEBF-II.45	SEBF-II.55
Dimension. mm	A	3380	3380	3380	3380
	B	1940	1940	1940	1940
	C	2420	2420	2420	2420
	D	4200	4200	4200	4200
Weight, kg (approx)		3320	3350	3400	3500
Max Vacuum, mbar		500	500	500	500
Air Volume m ³ /h (unloaded)		1855	2249	2617	3368
Electrical Motor, kW		30	37	45	55
Voltage Frequency, V/Hz		400/50	400/50	400/50	400/50
Main filter surface, m ²		15	15	15	15
Safety Filter Surface, m ²		20	20	20	20
Noise Level dB(A) (at 1 m distance)		65	67	67	70
Hose Pipe Connection, dia.mm		152	152	152	152
Layout		SD-10044	SD-10044	SD-10044	SD-10044

We reserve the right to alter any specifications without prior notice

Manufacturer:

DISAB-TELLA AB
Cedersdalsvägen 1
SE-186 40 Vallentuna
Sweden

Tel: +46 (0) 8 514 505 70
Fax: +46 (0) 8 511 754 66
E-mail: industrial@disab.com
www.disab.com

Distributor: