



## DISAB SEBF-II

### Usage

The DISAB SEBF-II is an electrical powered vacuum unit suitable for general cleaning and bulk suction in any industrial application where high capacity is required together with flexibility, mobility, reliability, and low noise level.

Together with a fixed pipe network this is a perfect central unit for smaller industry installations, but can also operate as a single suction unit using a 3" or 4" hose. Typical users include manufacturers of cement, lime, gypsum, tiles, chemicals, steel mills, cleaning contractors and more.

### Characteristics

DISAB SEBF-II is an electrical powered vacuum unit mounted in a solid metal frame with telescopic legs. To increase the pick-up capacity of this vacuum unit, it can work in conjunction with pre-separators i.e. vacuum skips.

Due to its flexibility the unit gets access to most areas where cleaning needs to be carried out without the use of a fixed pipe network, and for material that shall be recycled or collected in bags and similar.

### Benefits

The high suction capacity together with its flexible discharge system makes a DISAB SEBF-II very useful in most vacuum cleaning situations.

Other benefits include:

- Rigid design for industrial use.
- Filter system for dry and wet material.
- Automatic filter cleaning without compressed air.
- Several options for filters and other accessories.
- Engine power ranging from 30 to 55 kW.
- Control panel placed in dust-tight enclosure.
- Telescopic legs adjustable in height to fit most dust receivers.
- 63/125 amps electrical plug makes the unit usable in most industrial areas.
- High capacity using a Roots pump.
- The vacuum pump is equipped with a spring loaded safety valve regulating the vacuum not to exceed its maximum operating range.
- An exhaust silencer secures low noise operation.
- The filter system is equipped with a vacuum controlled ATM (air-repulse) filter cleaning system.

*A DISAB SEBF-II meets the high demands from the industry due to its efficiency, reliability, ease of operation and maintenance giving excellent value for money.*

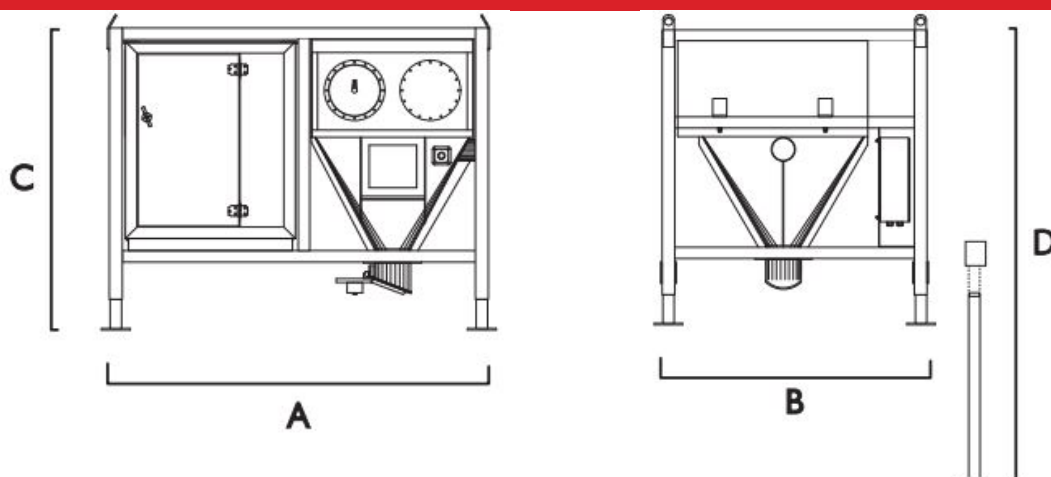

### Technical Data Chart for DISAB SEBF-II

Weight and Dimensions	SEBF-II.30	SEBF-II.37	SEBF-II.45	SEBF-II.55
A (mm)	3 380			
B (mm)	1 940			
C (mm)	2 420			
D (mm)	4 200			
Weight (kg, approx)	3 320	3 350	3 400	3 500

### Description

Vacuum pump	Three-Lobe Roots Pump			
Max vacuum, mbar	500			
Air volume m <sup>3</sup> /h (unloaded)	1 855	2 249	2 617	3 368
Electrical Motor, kW	30	37	45	55
Voltage Frequency, V/Hz	400/50			
Power Source	Electric			
Tank volume (m <sup>3</sup> )* *Excluding filter volume	1			
Total Tank Volume (m <sup>3</sup> )	2.8			
Dust bin	Conical hopper			
Main filter system (m <sup>2</sup> )	15			
Discharge	Big-bag, hopper, or other bin			
Noise Level dB(A) (at 1 m distance)	65	67	67	70

### Miscellaneous

Filter Class	L, M IEC EN 60335-2-69
Hose Connection	Dia 152 mm
Material	Steel S 235 JG2
Painting	System C2, RAL 3003 red