

DISAB Industrial Cleaning Machines



SkipVac, a small forklift handled high-capacity unit for medium vacuum duties

Suction Unit DISAB SkipVac™

The SkipVac suction unit meets the high demands from the industry due to its efficiency, reliability, ease of operation and maintenance giving excellent value for money.

The SkipVac is a powerful and compact suction unit, designed for suction of material and dust in industrial environments where the demands for efficient and reliable equipment are high. The unit is handled by a fork lift and powered by electric supply.

- Rigid design for industrial use
- Large built-in dustbin
- Filter system which can handle dry and wet material
- Self-tipping bin for easy discharge
- Filter cleaning without compressed air
- Low noise level
- 32 Amps electrical plug connection
- No dust valves or other moving parts involved, securing high availability factor and low maintenance costs.

WHY SkipVac

One of the most important problems to solve when planning a cleaning system is the handling of the collected dust and material. In order not to create new problems with dust and heavy lifting work in the premises, the optimal solution is to use the company's existing handling systems for the transportation and discharging of the collected dust. A fork lift is normally available in all industrial companies which is why the SkipVac unit is a flexible choice.

The high suction capacity together with the large collecting capacity makes the unit very useful in most

vacuum cleaning situations. Due to its flexibility the unit gets access to most areas where cleaning needs to be carried out without the use of fixed pipe networks or long hoses.

OPERATION

The vacuumed material is first separated in a specially designed fall-chamber. In this section the particles are guided and will also fall by gravity to the bottom of the container. From this section the air will be transported to the main filter section where any remaining dust will be separated.

As an option, the unit can be delivered with a built-in pneumatic jack for fixed installation.

APPLICATION

For general cleaning and bulk suction in any industrial application where high capacity is required together with flexibility, mobility, reliability and low noise level.

TYPICAL USERS

Manufacturers of Cement, Lime, Gypsum, Tiles, Concrete, Chemicals, Plastics, Fertilizer and Alumina. Foundries, Steel mills, Pulp-and Paper Industry, Quarries, Bakeries, Work Shops ...

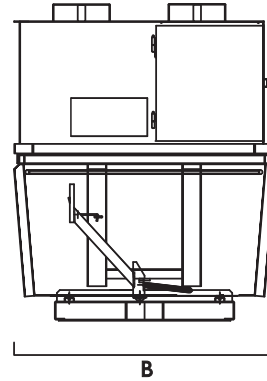
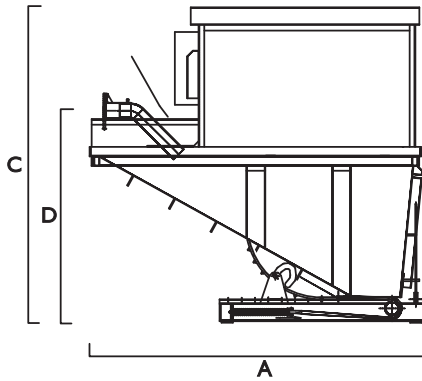

Suction Unit DISAB SkipVac™

VACUUM PUMP

The vacuum producer is a turbo pump of side channel blower type, with its electrical drive motor direct coupled and placed on a steel structured anti vibrated machine frame.

The vacuum pump is equipped with a spring loaded safety valve regulating the vacuum not to exceed its maximum operating range.

The drive part is built into an insulated steel enclosure to reduce noise level and fitted with a service door for access purposes.

MAIN FILTER

Filter compartment contains a cassette filter with flat filter bags, made of specially treated polyester needle felt. Service of filters is easy from the clean gas side on the outside of the unit.

As an option the filter system can be equipped with a manual or automatically vacuum controlled ATM (air-repulse) filter cleaning system. When activated, a large air inlet will ensure a fast backwards air direction through the filters, thus in an efficient way knocking off collected dust from the filter surface.

CONTAINER

The material container (dust bin) is directly connected to the filter compartment and the unit is designed for handling by a fork lift in all parts.

It has a tightly welded construction with external strengthening and has a balanced design for self tipping when the tipping lock is loosened. There is an extra mechanical security lock to ensure safety.

The top part is to be lifted off its guideways leaving the container free before tipping.

MISCELLANEOUS

Electrical Controls: 3-phase 400 V, 50Hz, aut. Star-/Delta-starter with motor protective switch, steel enclosure IP 65 with gauge.

Filter class: L, M IEC EN 60335-2-69

Material: Steel S 235 JG2

Hose connect: Ø102 mm

Painting: Surface treatment and painting according to class C2. Colour, RAL 3003 red

OPTIONS

- Aut.Repulse Filter Cleaning (ATM)
- Manual Repulse Filter Cleaning (ATM)
- Level Control; Paddle type (12V DC)
- Pneumatic Jack Stand, for lifting of Top Part
- Pre Designed for Remote Control 24 V
- DP-Switch, safety filter
- Timer Auto Stop
- Control Filter 10 m²

Item/Model	SkipVac SEFV-13	
Dimension. mm	A	1750
	B	1390
	C	1680
	D	1100
Weight, kg (approx)	910	
Max Vacuum, mbar	290	
Max Airflow m ³ /h	1100	
Filter Surface m ² (water-repelling)	5	
Dustbin Volume m ³ (approx.)	0,9	
Electrical motor kW	13	
Fuse A	32	
Noise Level dB(A) (at 1m/5 m distance)	75/70	
Layout	SD-10051	

We reserve the right to alter any specifications without prior notice

Manufacturer:

DISAB-TELLA AB
Cedersdalsvägen 1
SE-186 40 Vallentuna
Sweden

Tel: +46 (0) 8 514 505 70
Fax: +46 (0) 8 511 754 66
E-mail: industrial@disab.com
www.disab.com

Distributor: